

AMF-10

Automatic Mains Failure Control & Protection Module

Features

- Micro-processor auto control & protection
- Easy to read high light LED display
- Modularity design, easy to install
- Compact size with vibration protected
- IP65 rated waterproof front panel
- Provide full mains and genset alarms signals shutdowns
- All settings are stored in EEPROM and retained after power loss, no battery required.
- Universal LED graphic interface, displays ATS and genset status and failures
- Optional USB / RS485 / Ethernet remote communication functions
- Free APP for monitor and operate your ATS & genset directly from your smart phone



*Customized settings are auto-saved into memory and will remain even when power is off.

Protection & Alarm Status Indicators

- Engine Start Failure
- High Coolant Temperature
- Engine Over Speed
- Abnormal AC Voltage
- Low Fuel Level
- Maintain Service Alarm
- Emergency Stop
- Low Oil Pressure
- Engine Under Speed
- Generator Over Load
- Abnormal Battery Voltage
- Two user definable inputs

4 Digit 7 Segment Easy-to-Read LED Display

- Programmable Display with 3 Phase Volts, Amp & Frequency
- Engine Operation Hours & Battery Voltage Display
- Internal Program Settings & Status
- Failure Signal Status by Graphic Display

Specifications

Power Input Voltage 9 to 36 Vdc (12V/24V)

Sensing Input Voltage 15 to 510 Vac

Frequency 50/60 Hz

Rated Output Capacity DC 10 Amps @ 12/24 Vdc

AC 8 Amps @ 250 Vac

CT Specification Burden Above 2.5 VA

CT Secondary Rated Amps 5A

Power Dissipating Max. 5 watts

Dimensions

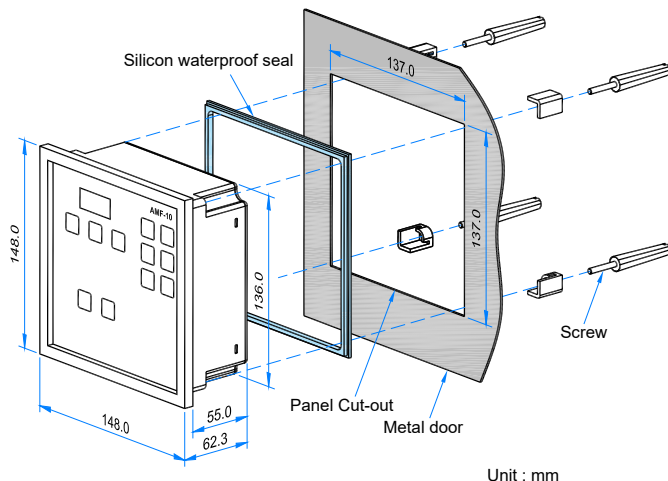

Unit : mm

Environment

Operating Temperature -20 to +60 °C

Relative Humidity Max. 95%

Max. Vibration 5 to 25 Hz +/-1.6 mm

25 to 100 Hz a=4g

Physical Specifications

Panel Cut-Out 137.0 x 137.0 +/-0.5 mm

Dimensions 148.0 (L) x 148.0 (W) x 62.3 (H) mm

Weight 589 g +/-2%



KUTAI ELECTRONICS INDUSTRY CO., LTD.

TEL : +886-7-8121771 FAX : +886-7-8121775 Website : www.kutai.com.tw

Headquarters : No.3, Ln. 201, Qianfu St., Qianzhen Dist., Kaohsiung City 806037, Taiwan

